

# Research in Bandpass Filters Integrated with Passive and Active Circuits

Li Gao, and Xiu Yin Zhang

**Abstract**—With the support of IEEE MTT-S UG Scholarship, a series research about bandpass filters have been carried out. These include a compact tri-band bandpass filter using eight-mode resonator for 5G application, a tunable balanced filter with high common-mode suppression, and a tunable filtering power divider with constant absolute bandwidth. They are published on *IEEE Microwave and Wireless Component Letters*, *IET Electronics Letters*, and *IEEE Transaction on Microwave Theory and Techniques*, respectively. The following parts will display these researches in detail.

## I. RESEARCH

### A. Tri-Band Bandpass Filter

In this paper [1], we presented a novel compact tri-band bandpass filter (BPF) with wide third passband to satisfy the requirement of 5G WiFi. The proposed filter utilizes a novel multi-stub-loaded resonator with eight resonance modes. By utilizing these modes, a tri-band BPF with controllable operating frequencies is designed. Among the three bands, the highest one is formed by four modes to cover the 5G WiFi band. Each of the other two passbands centered at 2.4 and 3.5 GHz is realized by two modes. To validate the proposed idea, an filter is implemented. Good agreement between the predicated and measured results demonstrates the proposed idea.

Fig. 1 shows the structure of tri-band bandpass filter and Fig. 2 shows the simulated and measured results.

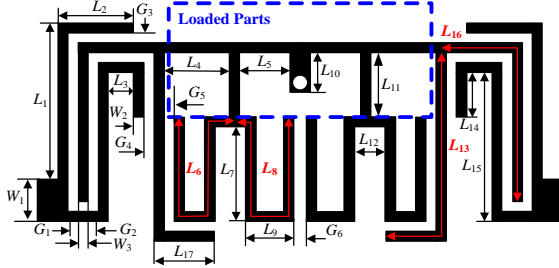

Fig. 1. Structure of proposed tri-band bandpass filter.

### B. Tunable Balanced Filter

This paper [2] presents a novel tunable balanced bandpass filter with high common-mode suppression by using discriminating coupling. Four half-wavelength resonators terminated with varactors are utilized to obtain the tunable responses. The high common-mode (CM) suppression is

L. Gao was with the School of Electronic and Information Engineering, South China University of Technology, Guangzhou, 510641, China. Now, he is the Department of Electronics and Computer Engineering, University of California, San Diego, La Jolla, 92093, USA

X. Y. Zhang is with the School of Electronic and Information Engineering, South China University of Technology, Guangzhou, 510641, China.

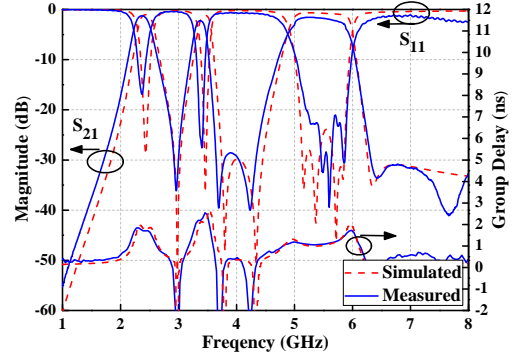

Fig. 2. Simulated and measured results of the tri-band bandpass filter.

realized by discriminating coupling between feeding structures and resonators, which blocks the CM signals. An experimental tunable balanced bandpass filter is implemented which achieve the continuous tuning range from 0.84 GHz to 1.15 GHz and more than 50 dB common-mode rejection levels.

Fig. 3 shows the structure of tunable balanced bandpass filter and Fig. 4 shows the simulated and measured results.

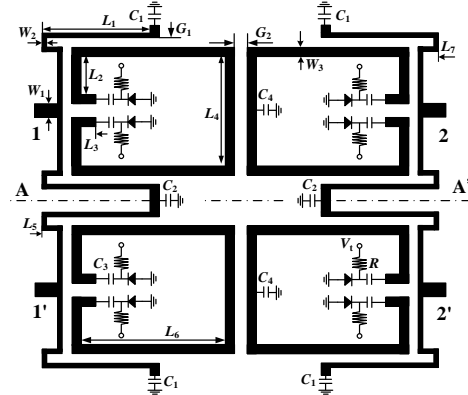

Fig. 3. Structure of tunable balanced bandpass filter.

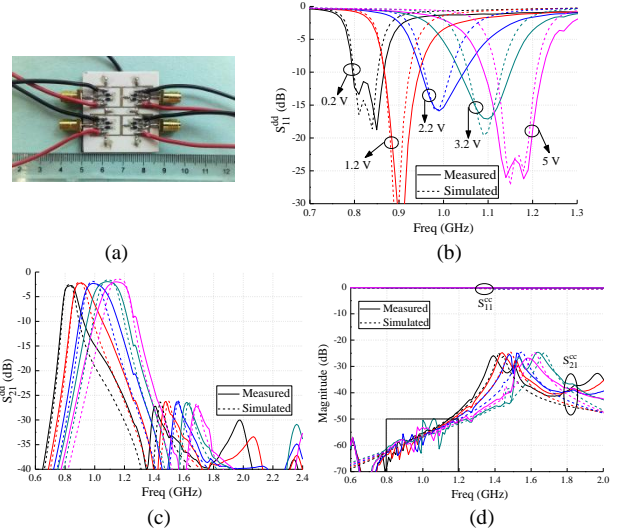

Fig. 4(a) Fabricated circuit; simulated and measured (b)  $S_{11}^{dd}$ ; (c)  $S_{21}^{dd}$ ; (d)  $S_{11}^{cc}$  &  $S_{21}^{cc}$

### C. Tunable Filtering Power Divider

This paper [3] presents a novel frequency-agile filtering power divider with constant absolute bandwidth and high selectivity. The proposed design utilizes four coupled resonators to obtain the two functions of power division and filtering. Synthesis of the filtering power divider is carried out and the design guidelines are given. Then, varactors are loaded to the resonators to enable frequency tuning. By using capacitors as well as magnetic and electric coupling to obtain required external quality factors and coupling coefficients, a constant absolute bandwidth is maintained when tuning the frequency. To demonstrate the validity of the proposed design, a circuit was fabricated. Experimental results show that the operating frequency can be changed from 0.62 to 0.85 GHz with the 3 dB absolute bandwidth of  $60 \pm 2.5$  MHz. Moreover, transmission zeros are generated near the passband, resulting in high selectivity for each tuning state. Comparisons between the measured and simulated results are presented and good agreement is observed.

Fig. 5 shows the structure of tunable balanced bandpass filter and Fig. 6-7 shows the simulated and measured results.

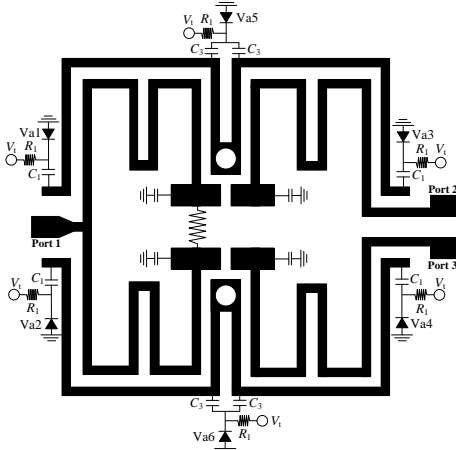

Fig.5 Configuration of the proposed tunable filtering power divider.

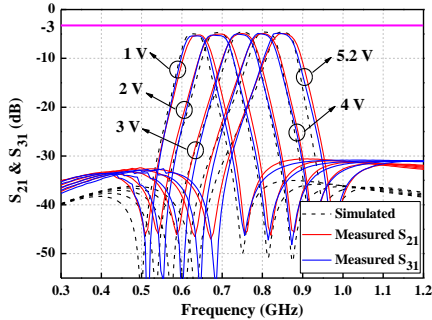

Fig. 6 Simulated and measured  $S_{21}$  and  $S_{31}$

## II. NEXT CAREER

With the support of IEEE MTT-S, I published several journal papers and these achievements are approved by University of California, San Diego (UCSD). Now I am pursuing PhD degree in Department of Electronics and Computer Engineering, UCSD and focus on designing RFIC. My supervisor is Prof. Gabriel. M. Rebeiz.

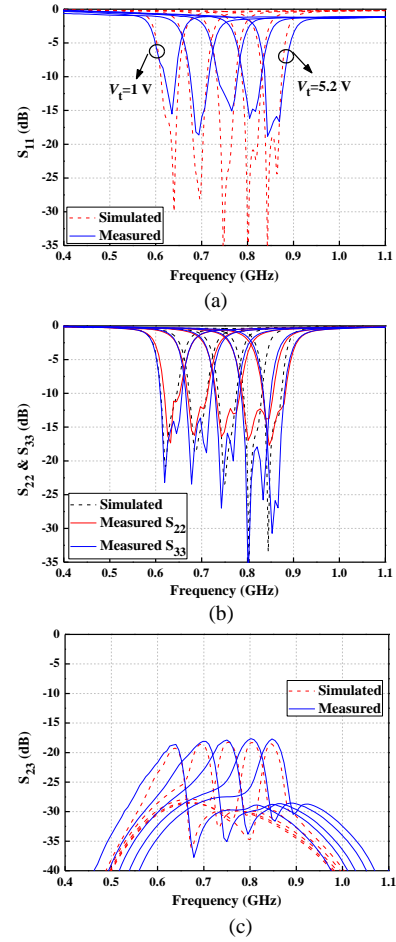

Fig. 7 Simulated and measured (a)  $S_{11}$ ; (b)  $S_{22}$  and  $S_{33}$ ; (b)  $S_{23}$

## ACKNOWLEDGMENT

The authors would like to thank IEEE MTT-S, who supports me to attend the conference of *IEEE MTT-S International Microwave Workshop Series on Advanced Materials and Processes for RF and THz Applications*. During this conference, I met many famous professors (IEEE Fellow). Their passion and persistence on research impressed me deeply, which also inspired me to pursue a PhD degree and become an excellent RF/Microwave researcher or engineer.

## PUBLICATIONS

- [1] L. Gao, X. Y. Zhang, and Q. Xue, "Compact tri-band bandpass filter using novel eight-mode resonator for 5G WiFi application", *IEEE Microw. Wireless Compon. Lett.* vol. 25, no. 10, pp. 660-662, Oct. 2015.
- [2] X. L. Zhao, L. Gao, and J. -X. Xu, "Tunable balanced bandpass filter with high common-mode suppression," *Electronics Lett.*, vol. 51, no. 24, pp. 2021-2023, Nov. 2015.
- [3] L. Gao, X. Y. Zhang, and Q. Xue, "Compact tunable filtering power divider with constant absolute bandwidth", *IEEE Trans. Microw. Theory Tech.* vol. 63, no. 10, pp. 3505-3513, Oct. 2015.
- [4] X. L. Zhao, L. Gao, J. -X. Xu, Y. Zhang, and J. Xiang, "High-selectivity dual-band filtering power divider using stub-loaded quarter-wavelength resonator", *Journal of Electromagnetic Waves and Applications*, vol. 29, no. 16, pp. 2216-2223, Nov. 2015. (Corresponding author)
- [5] Y. Zhang, L. Gao, and X. Y. Zhang, "Compact quad-band bandpass filter for DCS/WLAN/WiMAX/5G Wi-Fi application", *IEEE Microw. Wireless Compon. Lett.* vol. 25, no. 10, pp. 645-647, Oct. 2015.
- [6] J. -X. Xu, L. Gao, J. Xiang, and Q. Xue, "Compact tri-band bandpass filter with controllable frequencies," accepted by *Microwave Optical Technology Letter.* (Corresponding author)